



## Modelling of High Energy Impacted Ball Milling and Ball Motion by Finite Element Analysis

Ali Rıza AKTAŞ<sup>1,\*</sup>, Gülsün AKTAŞ<sup>1</sup>, Metin GÜRÜ<sup>1</sup>

<sup>1</sup>Faculty of Engineering, Department of Chemical Engineering, Gazi University, 06570 Maltepe, Ankara, Turkey

### Article Info

Received: 29/10/2016  
Accepted: 27/04/2017

### Keywords

High energy impact,  
Finite element analysis,  
SPEX<sup>®</sup> 8000,  
Reactor/ball velocity,  
ANSYS<sup>™</sup>.

### Abstract

SPEX<sup>®</sup> 8000 Mixer/Mill is a high-energy ball mill which is used mostly for laboratory scale processes. This study deals with an investigation on reactor and ball velocities of SPEX<sup>®</sup> 8000 Mixer/Mill by finite element method for different shaft frequencies. Ball collisions in milling devices are governed by complex dynamics ruled by unpredictable impulsive forces. The analysis of reactor motion and ball in the reactor are carried out by using transient structural and rigid dynamics analysis systems of ANSYS<sup>™</sup> software. Velocity/acceleration values of reactor and velocity of ball at 115 rad s<sup>-1</sup> obtained from the analysis are compared with mathematical models in the literature. The results obtained from analyzes are in accordance with the mathematical model has proved the correctness of the analysis model. Kinematic variables for empty reactor and ball are obtained for different shaft frequencies by using the same analysis model. Thus, the purpose of this study is to calculate the working frequency of SPEX<sup>®</sup> 8000 Mixer Mill for different type of materials.

## 1. INTRODUCTION

High energy impacted ball mills are new technology machines which are used for mechanical alloying, mechanochemical reactions and size reduction. Mechanical alloying is used to produce energetic, nanocrystalline, and other advanced alloys which cannot be produced by conventional processes [1,2]. By high-energy mills, raw materials are grinded to obtain powder. Advanced materials have been prepared mostly by mechanical alloying [3- 5]. Mechanical alloying process is more simple and economical than conventional processes. Increasing efficiency of mechanical alloying equipment (i.e. ball mills, roller mills, hammer mills etc.) and simulation studies have become an important area of interest recently. Mechanical alloying process has a large number of operating parameters and to determine the all parameters are very difficult. Particle size, structure, composition, and crystallinity of powder, impact energy from collision, ball velocity, and reactor velocity are the operating conditions to be handled. In addition, simulation and comparisons are complicated [5].

The most important usage areas of ball milling are size reduction, mechanical alloying and solid phase reaction. Nanoparticles have improved chemical, physical and mechanical performances when compared to the microparticles. Using ball mill machines to product nano sized powders is one of their important usage aims [6- 8]. Another important usage area is mechanical alloying. It is a type of powder processing technique that involves repeated cold welding, fracturing and rewelding of powder particles in a high-energy ball mill [2, 9, 10]. Solid phase reaction is similar to mechanical alloying process but reaction takes place in the ball milling [11,12]. Mechanical alloying and solid phase reactions in the ball milling provide cheaper and easier process compared to commercial ones.

Few studies about mathematical modeling of mechanical alloying have been found in the literature. Particle size distribution during mechanical alloying has been studied with differential-integral equation [13,14] and models based Smoluchowski's coagulation–fragmentation equations [15].

The empty reactor's velocity and acceleration have already been calculated for 115 rads<sup>-1</sup> by the nonlinear dynamic numerical modeling technique. The maximum velocity and acceleration were found

\*Corresponding author, e-mail: [aktas.ar@gmail.com](mailto:aktas.ar@gmail.com)

approximately  $3 \text{ ms}^{-1}$  and  $320 \text{ ms}^{-2}$  respectively in the x axis direction. However, the effect of spring is not included in the analysis at that study [9].

In another study, a new model for one ball motion which includes wall-ball collision was created (Concas et al., 2006). Throughout the process, position, speed and acceleration of each point of reactor and ball have to be determined to measure the impact exerted between ball and reactor wall. Therefore, three-dimensional reactor motion is simulated according to the mechanism. Two Cartesian coordinate systems are chosen for the simulation. The movement of each point of the reactor is simulated with respect to a fixed system. The fixed system is the mechanical shaft arm and its points are coincided with the center point of the arm. Other is the dynamic coordinate system disposed at the center of the cylindrical reactor. The trajectory of each point of the reactor (according to the fixed system) has been simulated to synchronize harmonic motion of the arm connected to the dynamic coordinate system. Primarily for the simulation of the movement of the reactor, mathematical algorithm for the assessment was adopted to the ball-wall of reactor interaction and collision. By this algorithm, reactor motion is simulated and collisions between ball and wall of a reactor are examined. From the numerical solution of this model, minimum, maximum, and average impact velocities are calculated as  $0.09 \text{ ms}^{-1}$ ,  $7.61 \text{ ms}^{-1}$ , and  $4.168 \text{ ms}^{-1}$  respectively. But this study doesn't include damping ratio and the impact energy absorption of materials [16].

A statistically optimized experimental strategy to increase the efficiency of comminution processes requires a significant human and economic effort. So, mathematical modeling and simulation codes may represent important and cost-effective tools for predicting process performances, scaling up and optimizing comminution equipment. In particular, an effective mathematical model should be able to simulate the grain-size distribution of powders properly during comminution processes as a function of geometric and operating mill variables (i.e., impact frequency and energetic input) as well as characteristics of milled powders.

The purpose of this study was to investigate a modelling of high energy impacted ball milling and ball motion by finite element analysis. In addition, the impact velocity of ball and velocity/acceleration of reactor for different shaft frequencies were determined by using the finite element method in a commercial program. The modeling of the motion and collision of balls as a multi-body system is not easy analyze in ANSYS™ program. Finite element method analysis of SPEX® 8000 Mixer/Mill cannot be found in the literature. This SPEX analyses in the previous studies [9, 15] were done only for  $115 \text{ rad s}^{-1}$  by using mathematical modeling. In this study, the multi body motion was analyzed firstly for 90-110-115-130  $\text{rad s}^{-1}$  of shaft frequencies by finite element method.

## 2. APPLICATION OF FINITE ELEMENT MODEL

The finite element method is a mathematical modeling technique to solve the complex systems by the combination of basic elements. A three-dimensional finite element model has been built for SPEX® 8000 Mixer/Mill to calculate distribution of velocity/acceleration values of reactor and velocity of rigid ball. Modelled system geometry is shown in Figure 1.

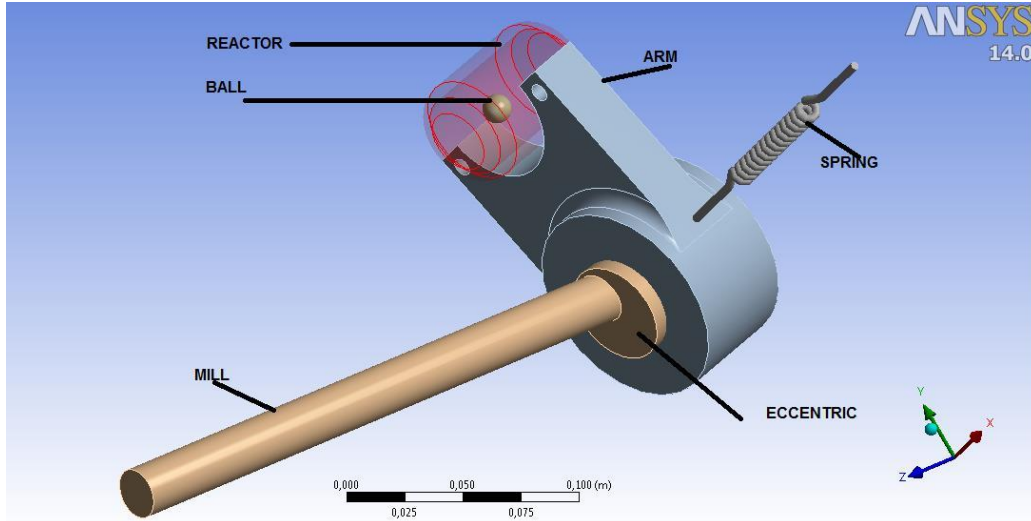

**Figure 1.** System modeled by ANSYS™ Design Modeler

As shown in Figure 1, SPEX® 8000 Mixer/Mill system is consisted of 4 parts; mill, arm, reactor and ball in the reactor. A spring present in the ANSYS™ program is used for fixing the system. Three dimensional model is developed to simulate the motion of balls in a reactor connected to SPEX® 8000 Mixer/Mill. The material properties used in the model are given in Table 1.

Motor and pulley located on the SPEX® 8000 Mixer/Mill drive the mill in  $90\text{-}130\text{ rad s}^{-1}$ . This rotational motion is transmitted to mill by an eccentric connection part. Spring gives additional constrain at radial axis to the arm with bearing at the center. However, the reactor has the eccentric rotational freedoms in 3-axis. The reactor's velocity/acceleration and ball's velocity values are determined from analyze and compared to the results obtained [9, 16].

Table 1. Parameters used in the numerical analysis

Parameter	Value	Unit	Source (Ref. No)
Internal reactor radius	1.9	cm	Concasa et al (Concas et al., 2006)[16]
Internal reactor length	5.8	cm	Concasa et al. (Concas et al., 2006)[16]
Arm length	10	cm	Concasa et al. (Concas et al., 2006)[16]
Ball radius	6.3	mm	Concasa et al. (Concas et al., 2006)[16]
Number of ball	1		Assigned
Ball weight	8.114	g	Concasa et al. (Concas et al., 2006)
Mill frequency	90-130	rad s <sup>-1</sup>	SPEX (Spex Sample Prep,2003)[18]
Ball density	7700	kg m <sup>-3</sup>	Pöschel et al. (Poschel et al.,2001)[17]
Young's modul	$20.6 \times 10^{10}$	Pa	Pöschel et al. (Poschel et al.,2001) [17]
Poisson's ratio	0.29		Pöschel et al. (Poschel et al.,2001) [17]

Modeling in the study of other researchers [16] is followed for validation with the values in Table 1. Due to long time requirement for iterations during dynamic ball motion analyzes, analyzes are limited to 0.3 second for returning motion of mill at  $115\text{ rad s}^{-1}$  as in other studies [9, 16].

Transient static structural analyses and then rigid dynamic analyses are carried out. The reason for using two modules separately is that the transient static structural module gives more reliable results but solution is taken long time. Therefore, after first results obtained from transient static structural module, rigid dynamics module used to speed up the solution process.

Enough contact between meshed structures of components is set. 15941 element in transient structural module and 3605 element in rigid dynamics module were created after meshing process. Analyses were done in two steps for achieving more realistic results and being close to the actual system. In first step during 0.1 second mill is rotated at 0 to 115 rad s<sup>-1</sup> and in second step during 0.2 second at 115 rad s<sup>-1</sup> constant speed.

Initial, minimum, and maximum time steps are chosen as 0.002 second, 0.0000001 second and 0.05 second, respectively. During this analysis, gravity is neglected. Analyses are repeated for 90 rad s<sup>-1</sup>, 110 rad s<sup>-1</sup>, 115 rad s<sup>-1</sup>, and 130 rad s<sup>-1</sup>.

### 3. RESULT AND DISCUSSION

As a result of transient structural analysis; the maximum, minimum, and average velocities of ball at 115 rad s<sup>-1</sup> frequency are conducted as 0.001 ms<sup>-1</sup>, 7.279 ms<sup>-1</sup> and 4.096 ms<sup>-1</sup>, respectively. From rigid dynamics analysis; corresponding values are obtained as 0 ms<sup>-1</sup>, 7.71 ms<sup>-1</sup> and 4.05 ms<sup>-1</sup> respectively. It shows a good agreement with numerical solution of previous study done by other researchers (Concas et al., 2006).

Similarly, results from previous analysis done by other researches [9] at 115 rad s<sup>-1</sup> are validated and given at Figure 2 and Figure 3 respectively. Different operating frequencies of empty SPEX<sup>®</sup> 8000 Mixer/Mill reactor and ball velocities were not analyzed before.

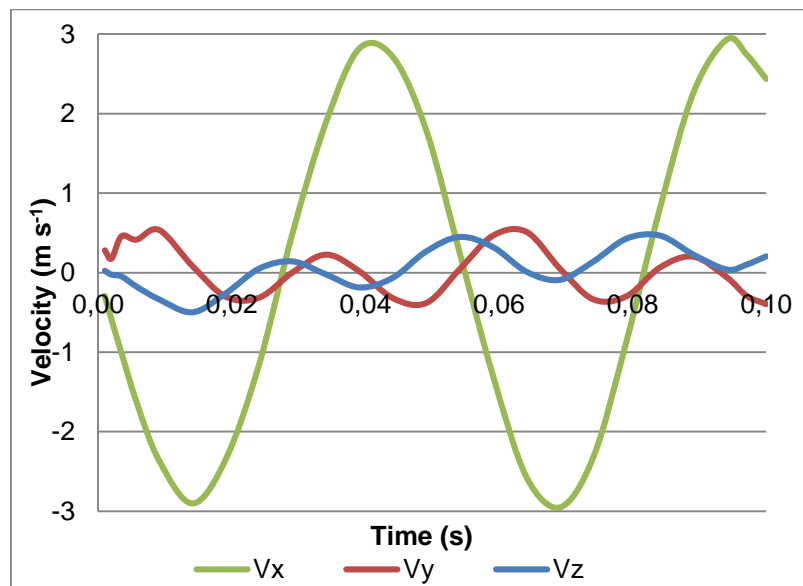

**Figure 2.** x, y, and z components for velocity for empty reactor at 115 rad s<sup>-1</sup> circular speed.

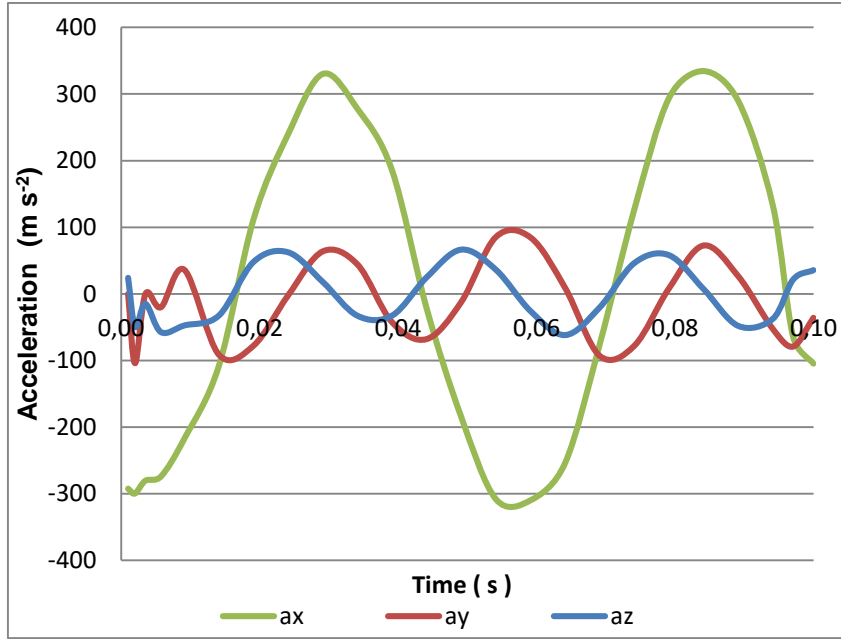

Figure 3. x, y, and z components for acceleration for empty reactor at 115 rad s<sup>-1</sup> circular speed.

SPEX<sup>®</sup> 8000 Mixer/Mill frequency has been reported as 90 to 130 rad s<sup>-1</sup> (Spex Sample Prep,2003). Therefore, another analyzes are carried out for 90, 110 and 130 rad s<sup>-1</sup> to determine the empty reactor’s velocity change versus mill frequency. The highest velocity/acceleration values are conducted for 115 rad s<sup>-1</sup> frequency in the x component as seen in Figure 2 and Figure 3. Hence, velocity and acceleration analysis of the empty reactor for different frequencies are performed for only x-axis and shown in Figure 4 and Figure 5 respectively.

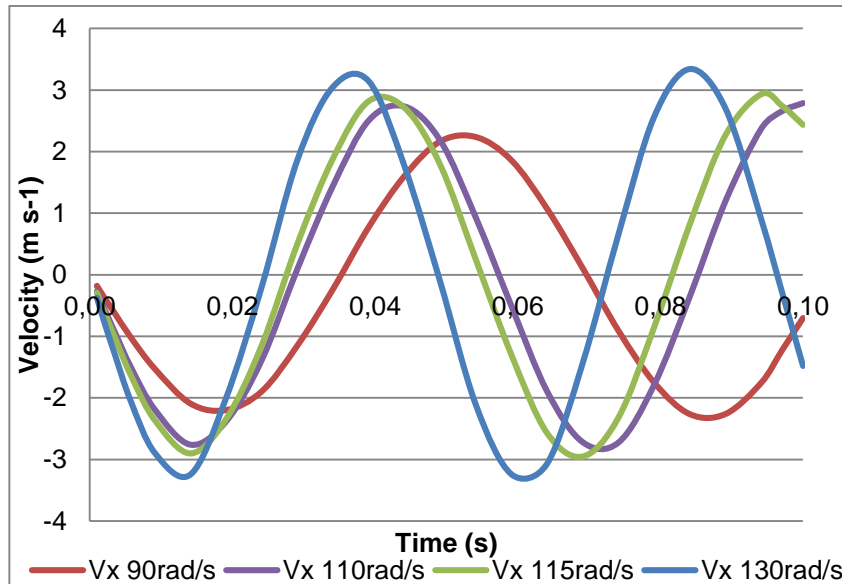
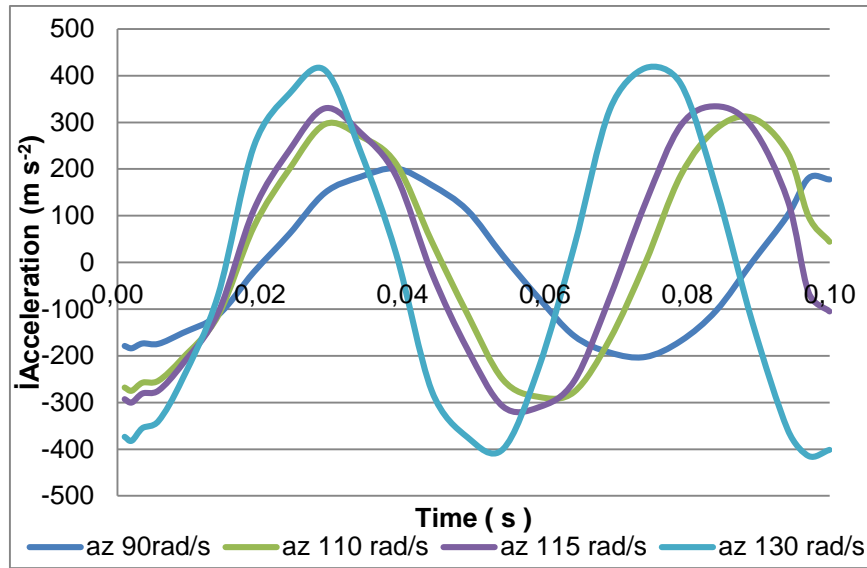
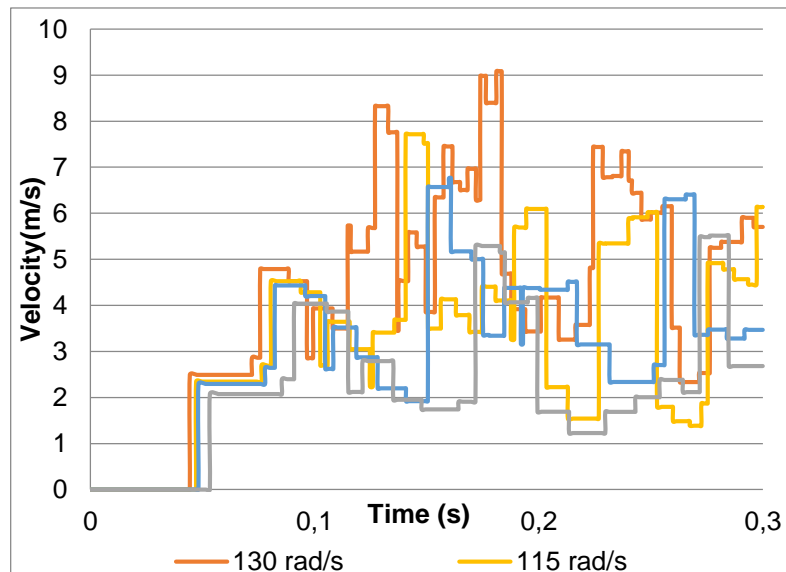

Figure 4. The x component of velocity in empty reactor case for 90, 110, 115 and 130 rad s<sup>-1</sup> frequencies



**Figure 5.** The x component of acceleration in empty reactor case for 90, 110, 115 and 130  $\text{rad s}^{-1}$  frequencies

As seen in Figure 4 and Figure 5, the velocity and acceleration of the empty reactor increase by increasing mill frequency as expected. It will lead the mill machine to seesaw in shorter time for the same displacement. Changes in the velocity of the ball in the reactor are given in Figure 6.



**Figure 6.** Ball's velocity profile for 90  $\text{rad s}^{-1}$ , 110  $\text{rad s}^{-1}$ , 115  $\text{rad s}^{-1}$ , 130  $\text{rad s}^{-1}$  frequencies

It is seen that all velocity profiles for all frequencies are similar in the first time zone of 0.1 second from Figure 6. Tolerable difference in the 0.1 second velocity profile is due to increment in the frequency occurred within an earlier time zone. The velocity profiles for all frequencies in the 0.2-second time-zone have different shapes. The reason of this difference can be interpreted as a result of much faster increment in the acceleration of ball motion and collisions from wall-ball interaction in the reactor during acceleration. This increment in the collision quantity changes the velocity profile.

#### 4. CONCLUSION

The advanced technology materials, which cannot be produced by conventional methods, are manufactured by methods such as size reduction, solid-state reactions and mechanical alloying. For these production methods, different mill types may be used. SPEX<sup>®</sup> 8000 Mixer/Mill is the highest energy-impacted mill used mostly in laboratory studies. In our study, SPEX<sup>®</sup> 8000 Mixer/Mill system was modeled with ANSYS<sup>™</sup> Design Modeler and analyzed by using transient structural method. The maximum, minimum, and average velocities of ball for 115 rads<sup>-1</sup> frequency were evaluated as 0.001 ms<sup>-1</sup>, 7.279 ms<sup>-1</sup> and 4.096 ms<sup>-1</sup>, respectively. Since velocity was the highest in the x-axis, analyses for different frequencies were carried out for only x-axis for empty reactor. Both of velocity and acceleration increase by increasing frequency. Consequently, it will be easier to select proper frequency and milling time to achieve the desired particle size distribution just in time anymore by using these experimental results.

Production of new experimental systems or devices to improve the efficiency of mechanical alloying and milling processes, very large manpower and money is spent. Manpower and budget spent for such systems can be reduced by finite element methods by modeling the working conditions of these devices. Once a reliable analyses technic is obtained, system parameters (spindle speed, reactor size, etc.) can be varied to any values to be evaluated. Appropriate results can be observed for different devices before manufacturing easily anymore.

Effect of reactor radius, reactor length or ball radius on velocity and acceleration can be determined by performing similar analyzes. In addition, proper reactor and ball can be selected easily for mechanical alloying, solid-state reaction and communitation.

#### ACKNOWLEDGEMENT

This study has been supported by the Scientific Research Project of Gazi University (under Project number 06/2012-48) and ETİ Mine Works (under Project number ETİ.TGD.2012/1). In addition to this, Gülsün Aktaş was awarded scholarships by Scientific and Technical Research Council of Turkey (TÜBİTAK-BİDEB).

#### CONFLICT OF INTEREST

No conflict of interest was declared by the authors

#### REFERENCES

- [1] Benjamin, J.S., Mechanical alloying – a perspective, *Met. Powder Rep.*, 45: 122–7, (1990).
- [2] Suryanarayana, C., “Mechanical Alloying and Milling”, *Prog. Mater. Sci.*, 46:1-184, (2001).
- [3] Schoenitz, M., Ward, T. and Dreizin, E.L., “Preparation of energetic metastable nano-composite materials by arrested reactive milling”, *Mater. Res. Soc. Symp.-Proc.*, 800: 85–90, (2003).
- [4] Zhang, D.L., “Processing of advanced materials using high-energy mechanical milling”, *Prog. Mater. Sci.*, 49(3–4): 537–600, (2004).
- [5] Ward, T.S., Chen, W., Schoenitz, M., Dave, R.N. and Dreizin, E.L., “A study of mechanical alloying processes using reactive milling and discrete element modeling”, *Acta Mater.*, 53: 2909–2918, (2005).
- [6] Hwang, S., Nishimura, C. and McCormick P.G., “Mechanical milling of magnesium powder”, *Mater. Sci. Eng.:A*, 318(1-2): 22-33, (2001).

- [7] Fecht, H.J., Hellstern, E., Fu, Z. and Johnson, W.L., “Nanocrystalline metals prepared by high-energy ball milling”, *Metall. Mater. Trans. A*, 21(9): 2333-2337, (1990).
- [8] Sözen, A., Özbaş, E., Menlik, T., Çakır, M., Gürü, M. and Boran, K., “Improving the Thermal Performance of Diffusion Absorption Refrigeration System with Alumina Nanofluids: An Experimental Study”, *Int. J. Refrig.*, 44: 73-80, (2014).
- [9] Caravati, C., Delogu, F., Cocco, G. and Rustici, M., “Hyperchaotic Qualities of the Ball Motion in a Ball Milling Device”, *Am. Inst. Phys.*, 9(1): 219-227, (1999).
- [10] Razavi, M., Irankhah, R. and Rahimpour, M.R., “Effect of milling of C and Ti as ceramic coating on the properties of 7Ch3 tool steel during plasmaspray process”, *J. Materials: Design and Applications*, 229(2): 137-145, (2015).
- [11] Arslan, D. and Gürü, M., “Mekanokimyasal yöntemle borkürbür sentezi ve alüminyum matrisli kompozit malzemede kullanılabilirliğin incelenmesi”, *J. Fac. Eng. and Archit. Gazi Uni.*, 28(4):875-883, (2013).
- [12] Çakanyıldırım, Ç. and Gürü, M., “Processing of LiBH<sub>4</sub> from its elements by ball milling method”, *Renew. Energy*, 33(11): 2388-2392, (2008).
- [13] Aikin, B.J.M. and Courtney, T.H., “Modelling of particle size evolution during mechanical milling”, *Metall. Trans. A*, 24(11): 2465–71, (1993).
- [14] Aikin, B.J.M. and Courtney, T.H., “The kinetics of composite particle formation during mechanical alloying”, *Metall. Trans. A.*, 24(3):647–57, (1993).
- [15] Harris, J.R., Wattis, J.A.D. and Wood, J.V., “A comparison of different models for mechanical alloying”, *Acta Mater.*, 49(19): 3991–4003, (2001).
- [16] Concasa, A., Lai, N., Pisu, M. and Cao, G., “Modelling of Comminution Processes in Spex Mixer/Mill”, *Chem. Eng. Sci.*, 61: 3746 – 3760, (2006).
- [17] Poschel, T., Salueña, C. and Schwager, T., “Scaling properties of granular materials”, *Phys. Rev. E*, 64: 1-4, (2001).
- [18] Spex Sample Prep, “8000M Mixer/Mill Operating Manual”, USA, (2003).